

Using supply chain management to improve GIS units

by Dr. Peter Schmitz, Logistics and Quantitative Methods, CSIR Built Environment

The aim of supply chain management is to manage the suppliers, manufacturers and customers as a single entity to ensure that the whole chain is competitive at least cost to the whole chain. Goods in the context of this article are spatial datasets (GIS products) that have been produced by a GIS unit.

Dangermond [1] and Tomlinson [2] both provide a view on the future of geographic information systems (GIS) in the 21st century. The society will become more spatially enabled, meaning that geography and GIS will become embedded in mainstream decision-making and incorporated into enterprise systems such as SAP and as demonstrated in Oracle [1, 2 and 3]. One of the challenges according to Dangermond [1] and Tomlinson [2] for GIS units in the 21st century is to be able to manage themselves successfully in order to deliver the right product at the right time to the right customer [3]. Tomlinson [2] also indicated that there will be several management tools available to assist GIS units to enable them to manage themselves successfully. This article discusses such a management tool, namely supply chain management. The structure of the article is as follows: firstly the concept supply chains and supply chain management will be discussed. The second part will discuss first how the definition of GIS itself describes a supply chain and then the application of supply chains in the context of GIS and the third section will give an example of the use of supply chains at a GIS unit, namely ESI-GIS.

Supply chains and supply chain management

In order to understand the concepts of supply chains and supply chain management it is necessary to provide the definition of each concept. A supply chain according to Handfield and Nichols [4], is as follows:

"The supply chain encompasses all activities associated with the flow and transformation of goods from the raw materials stage (extraction), through to the end user, as well as the associated

information flows. Material and information flow both up and down the supply chain."

The basic supply chain consists of at least one supplier, a firm that manufactures a product using material and goods sourced from a supplier, and then delivers the product to at least one customer [5]. The management of this supply chain is known as supply chain management. Thus supply chain management can be defined as follows:

"The management of upstream and downstream relationships with suppliers and customers to deliver superior customer value at less cost to the supply chain as a whole [6]."

Supply chain management thus embraces strategic, tactical and operational management issues that will provide the company and the supply chain members with a competitive advantage over its competitors [7]. The following are managed in a supply chain [8]:

- Logistics, which includes the processing of orders received (from customers) and made (to suppliers); the inventory of available parts, work-in-progress and finished products; any transportation involved to move the parts, work-in-progress and finished goods; the warehousing of the aforementioned goods and parts; and the designing of the supply chain network. The supply chain network consists of the type and location of suppliers, the location of the warehouses and manufacturing plants and the type and locations of the customers.
- Materials management ranging from the establishment of production plans; the procurement of various materials based on materials requirement plan (MRP) and the

bill of materials (BOM) required for the production of goods; the inbound transportation of these materials; the receiving thereof and the payment of the suppliers to warehousing of these materials.

- Operations, which includes the use of forecasting methodologies to determine customer needs; the management of operations to produce the goods; and the quality management of the operations and the completed goods.
- Marketing, which includes advertising, customer relations, specials and the delivery of the right goods to the right customer at the right time and in the right condition [9].
- Other aspects that need to be managed are the use of third party logistics providers (3PL). These are logistics companies that handle the movement of parts and finished goods such as DHL, Fedex and UTi; global supply chains that link suppliers, manufacturers and customers from different countries; and the effective use of information and communication technologies. Examples of the latter are point-of-sale data from retailers; electronic fund transfers (EFT); the internet; and e-Commerce (both business-to-customer (B2C) and business-to-business (B2B)).

The Supply-Chain Council, which is a non-profit organisation in the United States with members from most of the big firms such as Boeing, Bayer, Lockheed-Martin and Toyota, designed a supply chain model in order to assist firms to model, analyse and manage the various aspects of the supply chain as discussed above. The model is the Supply-Chain Operations Reference (SCOR) model. The SCOR model divides the supply chain into five management processes, namely:

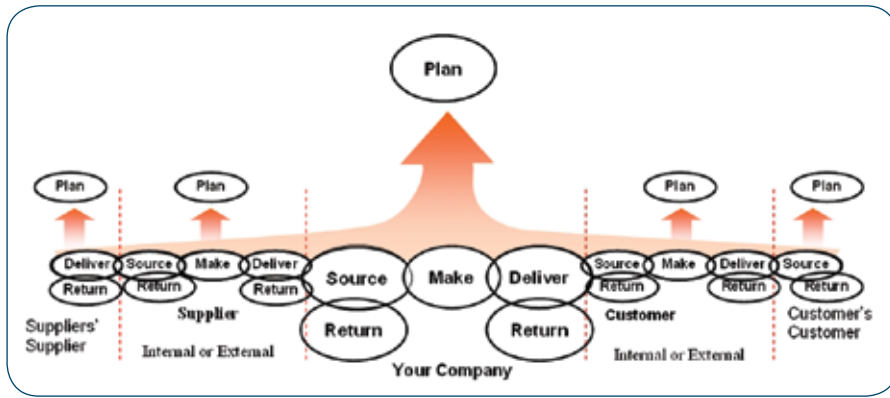

Fig.1: The SCOR model [11].

- *Plan (P)* – assessing and planning the supply chain.
- *Source (S)* – all the activities involved in sourcing the materials to manufacture the product.
- *Make (M)* – all the activities involved in making the product.
- *Deliver (D)* – all the activities involved in delivering the finished product either to a warehouse, distribution centre or the customer.
- *Return (R)* – which deals with processes involved when goods are returned to the company [10] and shown in Fig.1.

The SCOR model consists of three levels, namely the five management processes as given above, which is Level 1. Level 2 breaks each management process down into several process categories that are used to define the supply. There are three types of products created in the SCOR model, namely stocked products, make-to-order products (standard operating procedures are in place to create a product once an order is received) and engineer-to-order products (a customer specific product from design to end product is produced). Level 3 in turn breaks down each process category into various process elements that are needed to execute the process category. As an example process category Source Stocked Product (S1) of the management process SOURCE (S) is broken down into the following process elements: Schedule Product Deliveries (S1.1), Receive Product (S1.2), Verify Product (S1.3), Transfer Product (S1.4) and Authorise Supplier Payment (S1.5) [11].

This section briefly discussed the concepts of supply chains and supply chain management as it is currently used in the manufacturing and service industry. The SCOR model is an industry standard model that is used to model and analyse a supply chain to improve

the management of this chain. The next section will discuss the use of supply chains and supply chain management in the GIS environment.

GIS, supply chains and supply chain management

This section discusses the integration of supply chains and supply chain management into the environment of GIS. In order to integrate the abovementioned, it is necessary to provide first a definition of GIS to illustrate that GIS already intrinsically has the elements of a supply chain. The definition of a GIS is as follows:

“A GIS is a computer-assisted system, combined with appropriate infrastructures, resources and management, that acquires, stores, retrieves, transforms, manipulates and displays geographical and related non-geographical data [8]”.

Using supply chain terminology, the acquire part of the definition is similar to sourcing data from suppliers. In this paper data is used to describe geographical and related non-geographical as well as other data needed to create a data product by the GIS unit. The storing of data in the above definition can be seen as warehousing and inventory. Warehousing in the context of GIS is data warehousing and the inventory are the various datasets available to the GIS unit that are stored in the data warehouse. The retrieval, transformation and manipulation of the data are similar to manufacturing in the supply chain. The GIS unit retrieves the data from the data warehouse. The GIS unit then uses the GIS software to create a new dataset by manipulating and transforming the retrieved data from the data warehouse. Once the “manufacturing” process has been completed, the GIS unit can return

the new data to the data warehouse or send it directly to its customer. The customer then uses the GIS software to display the new data received. Other supply chain concepts as discussed in the previous section can be added as follows [8]:

- *Logistics*: Order processing, where the customer places an order for data at the GIS unit as well as the GIS unit placing orders at their suppliers for data; the transportation in the context of GIS can be the physical transport of a CD-ROM or other storage media to and from a GIS unit or the sending or receiving of data via the internet; and the creation of supply chain network is similar as discussed in the previous section.
- *Materials management*: Materials management in the context of GIS is the management of the data, the software, the hardware, and the peripherals (such as plotters, printers, LAN and servers) required to create new data. The other materials management aspect is the receiving and validation of ordered data from the suppliers as well as the management of the inbound transportation. An example of managing inbound transportation is when the GIS unit has to download purchased data which will only be available for a certain window period from a remote internet site. The GIS unit needs to ensure that it will be able to access the remote site and download the data during the defined window period. Part of materials management is the planning of the production operations, which will guide the materials (data, GIS software, etc.), required to create this new data. The use of cartographic models can assist in materials management.
- *Operations management*: It is the physical management of the creation of the new dataset by the GIS unit. The GIS unit could also make forecasts of customers’ needs based on past customer requirements and respond accordingly. Quality management includes the checking of the completeness of the data, the lineage of the data as well as the creation of the necessary metadata that is shipped with the new dataset.
- *Marketing*: Some GIS units are commercial enterprises that offer products and services. These GIS units market themselves via the internet or through the media that addresses their target market. The GIS units manage their customers to ensure that the customers

Performance attribute/category	Level 1 performance metric	2006/2007 study
Supply chain delivery	Delivery performance	73% of all orders received on time
Reliability	Perfect order fulfilment	68% of all orders received
Supply chain responsiveness	Order fulfilment lead time (days)	120 days (ESI-GIS delivers updates every 120 days to regional offices)
Supply chain flexibility	Supply chain response time (days)	43 (for ad hoc projects it is 3 days)
Supply chain costs	Costs of goods	87% (of total expenditure of R16 658 506,46)
	Total supply chain management costs	11% (of R16 658 506,46)
	Sales, general and administration costs	2% (of R16 658 506,46)
Supply chain asset management efficiency	Cash-to-cash cycle time (days)	161 (the number of days cash is tied up as working capital)
	Inventory days of supply (days)	34 (the number of days the cash is tied up as inventory)
	Asset turns	9,89 (for each rand spent, ESI-GIS makes R9,89)
Profitability	Gross margin	-17,88% (due to non-payment of customers – ESI-GIS ran at a loss)
	Operating income (margin)	-31,98% (see reason above)

Table 1: ESI-GIS SCOR Level 1 metrics [8].

will place orders for other datasets from these units.

- Other aspects of supply chain management in the context of GIS is the management of global supply chains where data such as Quickbird satellite imagery is ordered from overseas companies. Information and communications technology is used to transport data as discussed above as well as for e-Commerce.

From the above discussions the definition of a GIS supply chain can be given as follows [8]:

"The supply chains encompass all activities associated with the flow and transformation of spatial and attribute data from the raw data stage (capturing), through to the end user, as well as the associated information and money flows. Data, information and money flow up and down the supply chain."

This section gave an overview of the supply chains and supply chain management within the context of GIS. The next section gives an example of the application of supply chains and supply chain management to a specific GIS unit, namely ESI-GIS, a GIS unit in Eskom.

The application of supply chains and supply chain management in ESI-GIS

ESI-GIS is a GIS unit in Eskom that provides spatial data support to Distribution, which is responsible for the distribution of electricity to municipalities as well as to direct customers such as

farms and certain industries. The SCOR model as introduced in Section 2 has been adapted for the GIS environment and used to model ESI-GIS supply chain. Two studies were conducted, namely the 2004/5 and 2006/7 financial year. This section will give the highlights of the 2006/7 analysis. The methodology for the application of the adapted SCOR model is based on the work by Bollstorff and Rosenbaum [10]. The first step was to establish the business context of ESI-GIS including its financial statements, suppliers and customers. The complete spatial dataset range of ESI-GIS was used to map the supply chain. The next step was to establish the SCOR Level 1 metrics for ESI-GIS, which is given in Table 1.

The high costs of goods are due to huge capital investments by ESI-GIS in spatial data and other necessary data for the unit. The amount of money spent was R13 067 769,07. Labour costs were R1 497 645,41. Examples of improvement actions that ESI-GIS can make to its supply chain are to reduce labour cost by improving the skills of its staff, thus less time is spent on projects and to ensure that the data from suppliers are of sufficient quality and that ESI-GIS delivers quality data.

The next step was to determine problem areas within the supply chain by interviewing staff and to model the supply chain at SCOR Level 2, using the process categories of SCOR. Fig. 2 gives the supply chain including the problem areas within the supply chain.

The symbols used in Fig. 2 describe the various processes within the supply chain, thus P1 means the planning

of the complete supply chain, P2, P3 and P4 is the planning of sourcing the data, the production of the new data and the delivery of the data to the customer. P5 deals with the planning of the return of faulty data. S1 has been discussed under *supply chains and supply chain management*, whereas S2 and S3 are make-to-order and engineer-to-order products respectively that are sourced from suppliers. M1 describes the production (Make) of stocked data (i.e. data that can be immediately copied from the data warehouse and sent to a customer); M2 is the production of make-to-order data, where the data is made when an order is received and M3 is the production of engineer-to-order data that is in most instances a once-off project. M4 is a category that describes the maintenance process of existing datasets that need to be updated at regular intervals to keep them current. These datasets are then delivered as stocked data (D1). D2 and D3 are the delivery of make-to-order and engineer-to-order data to the customer respectively. DR is the delivery return of faulty data and SR the source return of faulty data.

The next step is to model the above supply chain at the process element (SCOR Level 3) level, which includes the capturing of best practices, ESI-GIS business rules and problems in executing the element. An example description of Level 3 process elements was provided earlier under "Supply chains and supply chain management". These identified problems are then linked to those identified at the beginning

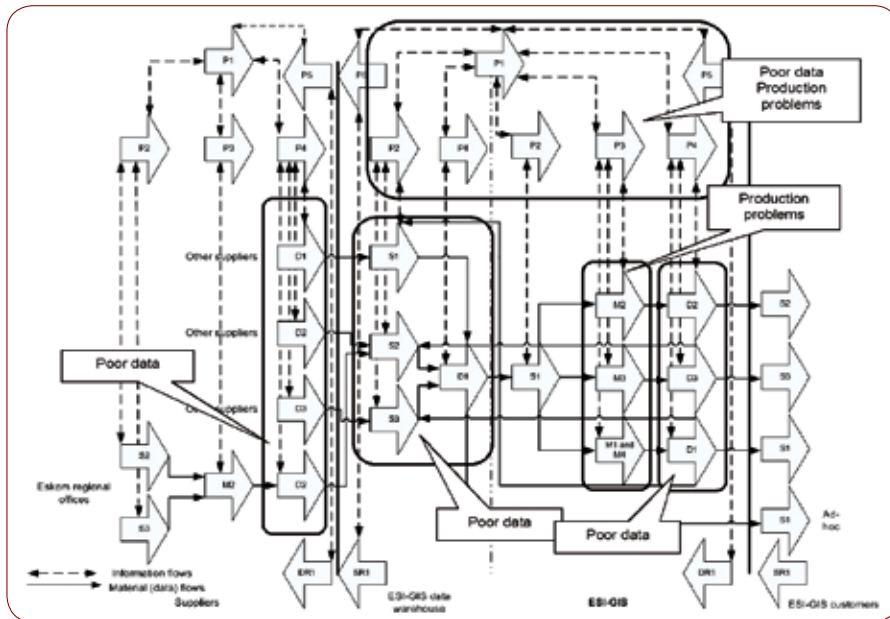

Fig.2: ESI-GIS supply chain model and problem areas [8].

of the process. A detailed discussion and illustration of the process elements (SCOR Level 3) is outside the scope of this paper. A monetary value is then added to each problem and a form of the Pareto Principle is used to identify problems that, when addressed, have the biggest financial impact on the unit. These problems are listed in Table 2.

The aim is to use the information captured at SCOR Level 3 to address the problem at the correct place within the supply chain. If ESI-GIS addresses these identified problem areas within the supply chain, there is then a possible savings of R288 400 per annum, which could in turn allow ESI-GIS to employ an additional resource without changing the budget. The additional resource will in turn bring further benefit to the unit and the supply chain involved.

Conclusions

The aim of using supply chains and supply chain management is first to make the whole supply chain visible by modelling it using the SCOR model. Once the supply chain has been modelled,

problems within the supply chain are identified and their impacts in terms of monetary value are calculated. Using supply chain management these problem areas within the supply chain can be addressed to realise the savings as well as improve the production and delivery cycle times of new data by ESI-GIS. The use of supply chains and supply chain management provides a structured approach to data production and thus allows for converting problems into opportunities to the benefit of the whole GIS supply chain. This is a new field and further research into this topic needs to be done. It is also advisable that if a GIS unit chooses to use supply chain management that a designated staff member or members should undergo training in supply chain management in order to ensure the proper application of this new management tool that is available to GIS units.

Acknowledgement

The author would like to acknowledge the generous cooperation of the staff and management of ESI-GIS and the CSIR for sponsoring the PhD research into this field as well as for FOSS4G 2008 for the

Problem	Monetary saving if addressed
Non-compliance with data standards	R82 400
Faulty data from suppliers	R44 000
Non-adherence to regulatory requirements	R44 000
Poor data quality	R40 000
Lack of advanced GIS skills	R28 000
Do not know what data are available	R25 000
ISO processes not updated	R25 000
Total	R288 400

Table 2: Savings by ESI-GIS when addressing identified problems [8].

opportunity to present my research.

This paper was presented at the FOSS4G 2008 Conference and is republished here with permission.

References

- [1] J Dangermond: The Future Favors GIS. ArcNews Online. Viewed on 7 April 2008. www.esri.com/news/arcnews/fall99/articles/03-futurefavors.htm 26 July 1999.
- [2] R F Tomlinson: An overview: the future of GIS. ArcNews Online, Winter 2000. Viewed on 7 April 2008. www.esri.com/news/arcnews/winter9900/articles/gis2000/30-tomlinson.html
- [3] GEO World: Industry Outlook 2005. GEO World, December, 2004. Viewed on 15 December 2004. www.geoplace.com/uploads/featurearticle/0412io.asp
- [4] R B Handfield and EL Nichols: Introduction to Supply Chain Management. Prentice Hall, Upper Saddle River, USA, 1999.
- [5] J T Mentzer: Fundamentals of Supply Chain Management – Twelve Drivers of Competitive Advantage. Sage Publications, Thousand Oaks, USA, 2004.
- [6] M Christopher: Logistics and Supply Chain Management: Strategies for Reducing Cost and Improving Service. 2nd Edition. Financial Times, Prentice Hall, Pearson Education Limited, Harlow, Essex, UK, 1998.
- [7] A G De Kok and S C Graves: Introduction. In De Kok, A.G. and Graves, S.C. (Eds) 2003: Supply Chain Management: Design, Coordination and Operations. Handbooks in Operations Research and Management Science, Vol. 11, Elsevier, The Netherlands.
- [8] PMU Schmitz: The use of supply chains and supply chain management to improve the efficiency and effectiveness of GIS units. Unpublished PhD Thesis, University of Johannesburg, Johannesburg, South Africa, 2008.
- [9] L Roberts: Supply Chain Management Certificate Program: Course notes. Course developed and presented by the Georgia Institute of Technology, Atlanta, Georgia and L. Roberts & Associates, Toledo, Ohio, USA, 2003.
- [10] P Bolstorff and R Rosenbaum: Supply Chain Excellence: A Handbook for Dramatic Improvement using the SCOR Model. AMACOM (American Management Association) New York, NY, USA. 2003.
- [11] Supply-Chain Council, 2005: Supply-Chain Operations Reference Model: Overview Version 7.0. Supply-Chain Council, Pittsburgh, USA. www.supply-chain.org

Contact Dr. Peter Schmitz
 CSIR Built Environment,
 Tel 012 841-3841,
 pschmitz@csir.co.za ©